

OPERATION & MAINTENANCE MANUAL

**Table-Top Autoclaves
models
1730, 2340, 2540, 3140, 3850, 3870 M & MK
1730MK Valueklave**



Booth Medical Equipment Warranty Policy for Booth Medical Refurbished Equipment

This Ship In Warranty Policy covers all AUTOCLAVES refurbished by Booth Medical Equipment.

The Warranty period for these autoclaves is **90 days** from date of receipt of the autoclave, unless otherwise noted on original Purchase Order.

Retain shipping box/boxes for the duration of the warranty period!

The warranty is considered parts and labor; ie. Booth Medical is responsible for providing all parts necessary to restore the autoclave to performance in accordance with factory specifications, and the labor necessary to install parts and make adjustments.

The Warranty does not cover cosmetics, such as scratched panels, minor wear and tear consistent with pre-owned equipment or user misuse or user error.

The typical flow of a warranty issue is:

Call Booth Medical Equipment to inform us of any warranty issue within the 90 day period.

Booth Medical requires that the purchaser provide an operator to work telephonically with a factory trained technician to try to resolve any issue. We ask that the operator provide accurate information about the nature of the problem. This insures timely resolution of minor issues. This usually takes 15 minutes to ½ hour.

If it is determined that the autoclave needs more in-depth technical attention, the purchaser is required to drain and re-box the equipment in the original shipping box and call Booth Medical for pick- up and return to Booth Medical. Booth Medical will be responsible for shipping costs for valid warranty issues.

You are responsible for retaining the shipping box and packing. If Booth Medical is required to provide boxes for shipping, you will be invoiced \$ 100.00 for the replacement box plus shipping charges to your location.

The unit will be restored to factory specifications and returned to the purchaser in a reasonable timeframe, usually a week to ten days.

The purchaser agrees to:

Retain shipping box/boxes for the duration of the warranty period.

Phone: 888-729-2332



www.boothmed.com

Read and understand the User manual (provided with Purchase) before use and specifically before requesting Warranty Support for the autoclave.

Provide operator assistance for telephonic technical support, usually 15 minutes.

Drain and box the autoclave for shipment.

Thank You

Booth Medical Equipment
7510 HWY 5 North
Alexander, AR 72002
888.729.2332

See our website at *[boothmed.com](http://www.boothmed.com)*

Phone: 888-729-2332



www.boothmed.com

Booth Medical Equipment Repair Policy

Thank you for choosing Booth Medical Equipment for your autoclave needs.

Overview: This document explains the usual course of events and fees associated with the repair of autoclaves at the Booth Medical facility. We provide premiere technical service for the Tuttnauer and Midmark/Ritter Autoclave models.

The usual progression of events consists of shipping the unit to our Facility in Alexander Arkansas. Upon arrival, your autoclave will be thoroughly inspected and an estimate of repairs will be prepared. You will be contacted, apprised of the estimate, and with your approval, the repairs will be completed, usually in 3 to 5 days, according to parts needed. The unit is then prepared for shipment back to the customer when the invoice is settled. If you do not approve the repair estimate, the unit will be re-boxed in preparation for shipment, and a fee of \$95.00 will be charged.

Fees associated with these events are as follows:

Technician time is billed at a rate of \$95.00 per hour.

All parts will be invoiced at usual retail rates, except in the case of a complete refurbishment, in which case the parts will be reduced 10%.

All shipping costs, to and from our facility, will be the responsibility of the customer. Customers are encouraged to arrange their own shipping. Customers are required to arrange shipping from anywhere outside of the lower 48 states.

If the Customer requests Booth Medical to arrange shipping, a flat rate of \$75.00 per shipping event will be charged. This fee includes carrier rates (FedEx Ground) for the lower 48 states. Midmark M11 and Tuttnauer 3870's required special shipping arrangements due to their size, and are handled on a case by case basis.

If the customer requires a box for shipping, one will be provided at a cost of \$100.00. There will be a \$ 25.00 refund when the box is returned to Booth Medical. The Customer is responsible for the cost of shipping the box.

Thank You

Booth Medical Equipment
7510 HWY 5 North
Alexander, AR 72002
888.729.2332

See our website at *[boothmed.com](http://www.boothmed.com)*



Wanted! - Dead or Alive



Cash Back for Your Old Autoclave

It doesn't matter If you buy a new autoclave from us or not, we will pay you Cash for your Manual or Automatic Steam Sterilizer WORKING OR NOT! we pay freight!

Call **888-729-2332** to speak with a Booth Medical Equipment representative about your autoclave.

Autoclave Maintenance Supplies 10% Off!

Use Coupon Code **t542**

<http://www.boothmed.com/autoclave-accessories.html>



[home](#) | [New Equipment](#) | [Pre-Owned Inventory](#) | [Repair Parts](#) | [Accessories](#) | [Autoclave Spec. Chart](#) | [Contact Us](#) | [Login](#) | [who we are](#) | [Tuttnauer Autoclave](#), [Midmark Autoclave](#), [Pre-owned Autoclaves](#), [Conmed Hyfreator 2000](#), [Burdick Atria EKG Machines](#), [Vital Signs Monitors](#), [Ritter Exam Tables](#)

Booth Medical Equipment
7510 Hwy 5 North
Alexander, AR 72002

Toll Free: 888-729-2332
Office: 501-847-2332
Fax: 501-847-2334
customerservice@boothmed.com

TABLE OF CONTENTS

PARAGRAPH	PAGE NO.
1 GENERAL.....	3
1.1 Incoming Inspection	3
1.2 Warranty.....	3
1.3 Warranty Statement	3
2 TECHNICAL DATA.....	5
2.1 Introduction	5
2.2 Storage conditions.....	6
2.3 Operating Condition.....	6
2.4 Standards.....	6
2.5 Construction.....	6
2.6 Utilities	6
2.7 Waste Water Disposal	7
2.8 Environment Emission Information.....	7
2.9 Dimensions.....	8
2.10 Technical Specifications	9
2.11 Electrical Data	10
2.12 Maximum Load Sizes.....	10
2.13 Symbol Description	10
3 DESCRIPTION OF COMPONENTS.....	13
3.1 Control Panel	13
3.2 Other Components	13
4 INSTALLATION INSTRUCTIONS.....	14
4.1 Electrical	14
4.2 Setup.....	14
4.3 Lifting and carrying.....	15
5 WATER QUALITY	16
6 PREPARATION BEFORE STERILIZATION	17
7 OPERATION	21
7.1 Loading and unloading the Device.....	21
7.2 Fill the Water Reservoir.....	21
8 SERVICE AND MAINTENANCE INSTRUCTIONS.....	26
8.1 Preventive and Scheduled Maintenance.....	26
8.2 Draining the Reservoir.....	27
8.3 Cleaning Air Jet	28
8.4 Replacing the Door Gasket	29
8.5 Checking the Safety Valve	30
8.6 Unclogging the multi-Purpose Valve or Fill piping.	31
9 CLEANING TABLE TOP AUTOCLAVES WITH CHAMBER BRITE™	32
10 TROUBLESHOOTING	34
11 LIST OF ACCESSORIES.....	44
12 CONVERSION TABLE	45

TABLE OF CONTENT (Cont.)

DRAWINGS	PAGE NO.
<i>Front View</i>	<i>11</i>
<i>Rear View</i>	<i>12</i>
<i>Tray Handle CMT240-0001</i>	<i>42</i>
<i>Pouch Rack</i>	<i>42</i>
<i>Tray</i>	<i>42</i>
<i>Tray Holder</i>	<i>42</i>
<i>Tray Holder</i>	<i>43</i>
<i>Alternative Tray Holder</i>	<i>43</i>

1

GENERAL



Read the Operating Instructions carefully, before beginning any operation on the autoclave!

1.1 Incoming Inspection

Upon receiving your Tuttnauer Autoclave carefully inspect the outside of the shipping carton for signs of damage. If any damage to the carton is found note the location with respect to the autoclave and check that area of the autoclave carefully once it is fully unpacked. Observe packing method and retain packing materials until the unit has been inspected. Mechanical inspection involves checking for signs of physical damage such as: scratched panel surfaces, broken knobs, etc.

If any damage is found contact your dealer as soon as possible so that they can file a claim with the shipping carrier and also notify Tuttnauer.

All Tuttnauer products are carefully inspected prior to shipment and all reasonable precautions are taken in preparing them for shipment to assure safe arrival at their destination.

Note: Lifting and carrying should always be done by two people.

1.2 Warranty

We certify that this instrument is guaranteed to be free from defects in material and workmanship for one year against faulty components and assembly.

This warranty does not include routine cleaning and preventive maintenance to be performed according to instructions in section 8.1 (Preventive and Scheduled Maintenance).

Tuttnauer warrants all new Manual autoclaves for a period of one full year, covering both parts and labor. This one year warranty covers defects in materials and workmanship on every part in the autoclave.

Tuttnauer warrants all chambers for a period of ten (10) years against defects in materials and workmanship. This chamber warranty went into effect January 1997.

This warranty does not apply to any instrument that has been subjected to misuse, neglect, accident or improper installation or application, nor shall it extend to autoclaves that have been repaired or altered outside the factory without prior authorization from Tuttnauer.

Tuttnauer's obligation is limited to the repair or replacement of parts for the autoclave. This warranty will be void if the unit is not purchased from an authorized Tuttnauer dealer. No other warranties or obligations are expressed or implied.

The Autoclave should only be used in a manner described in this manual!

1.3 Warranty Statement

To activate the warranty, the registration card must be completed and returned to Tuttnauer within fourteen (14) days of purchase or you may call our customer service department at the number listed below.

No product will be received or accepted for repair without prior return authorization from Tuttnauer. All transportation charges to and from Tuttnauer must be paid by the owner of the autoclave. During the first 90 days after purchase of an autoclave, Tuttnauer will pay shipping costs on an individually evaluated basis and **ONLY** with pre-approval.

Note:

If you have any questions or there are any difficulties with this instrument and the solution is not covered in this manual, please contact your dealer or our Technical Service Depts that can be reached at one of the following addresses. **Do not attempt to service this instrument yourself.**

☰ **Tuttnauer USA** Co. 25 Power Drive Hauppauge, NY, 11788, USA
☎: (800) 624 5836, (631) 737 4850, ☐Fax: (631) 737 0720
e-mail: info@tuttnauer.com

☰ **Tuttnauer Europe** b.v., Paardeweide 36, 4824 EH, Breda,
P.O. Box 7191, 4800 GD Breda, Netherlands. ☎+31/76-5423510,
☐Fax: +31/76-5423540, E-mail: Tuttnauer@tip.nl

2 **TECHNICAL DATA**

2.1 **Introduction**

This table-top autoclave is designed for the sterilization of wrapped and unwrapped instruments and related items found in dental, medical and veterinary clinics, first aid rooms, hospitals, laboratories etc.

This autoclave is an electrically - heated sterilizer using steam as the sterilizing agent. It is a manually operated device, with a control system based upon steam pressure.

The operator can select a sterilization temperature from within a range of 212°F - 273°F (100°C - 134°C). This allows for the sterilization of heat sensitive material at a low sterilization temperature, as well as providing for faster sterilization at higher temperatures for materials able to withstand the higher sterilization temperatures.

All models feature an easy to use control panel. The machines are ruggedly built using 316L stainless steel, copper, brass and aluminum. To guard against rusting no iron components are used. All models include a fully functioning drying system for wrapped items.

2.1.1 **Safety features**

The safety features include a double locking door mechanism (door tightening bolt and locking bellows), a mechanical pressure relief valve, over temperature thermostats and a double pole circuit breaker.

Pressure Door Lock System (Door Bellow)

The **Door Bellows** is a safety device that prevents the door from opening when the chamber is pressurized.

The system utilizes the build up of pressure in the chamber to expand a flexible Silicon-rubber bellows. The bellows then pushes a metal pin into a groove on the tightening bolt of the Door Closing Device.

This prevents the operator from opening the door when there is pressure in the chamber. When the steam is released, this bellow returns to its original position, drawing the pin with it and releasing the tightening bolt.

This manual is intended for the user and gives the user a general understanding of the instrument and the best ways to operate and take care of it in order to obtain optimum effective results.

After reading this manual, operating the autoclave will be easy. However since this instrument is built with high technology sensitive components, no attempt should be made by the user or any other unauthorized person to repair or recalibrate it.

Only technical personnel having proper qualifications and holding technical documentation (including a technician manual) and adequate information are authorized to service the apparatus.

2.2 Storage conditions

The packed or unpacked autoclave shall be stored in “indoor conditions” (protected from rain and water).

2.3 Operating Condition

This device is to be used for indoor use.

This autoclave is intended for NORMAL environment conditions as follows:

- - Altitude up to 2000m.
- - Minimum room temperature 41°F (5°C).
- - Installation Category II.
- - Pollution Degree 2.

The environment shall not exceed an ambient temperature of 40°C and a relative humidity of 50% up to a temperature of 31 °C and a humidity of 80%.

The sterilizer should be loaded only with autoclavable material.

2.4 Standards

2.4.1 Technical standards

1. A.S.M.E. Code, Section VIII div.1 for unfired pressure vessels.
2. AAMI/ANSI ST-55:2001 Table-Top steam sterilizers.
3. UL61010-1 General Safety.
4. UL61010-2-041 Particular Safety for Autoclaves.

2.4.2 Quality standards

1. EN ISO 9001:2000– Quality System
2. ISO 13485 – Quality systems – Medical devices – Particular requirements for the application of ISO 9001.

2.5 Construction

The main parts of the autoclave are made of materials as indicated below:

- ◆ Chamber is built of stainless steel 316 L.
- ◆ Door is made of stainless steel CF8.
- ◆ Trays are made of stainless steel 316.
- ◆ Door handle is made of hard plastic material that is safe to touch and thermo-insulated.
- ◆ Water reservoir is made of hard plastic material.

2.6 Utilities

Utilities	Unit	Value
Power supply (as appropriate)	V-A	1ph, 120V – 16A,50/60 Hz
	V-A	1ph, 230V – 16A,50/60 Hz



Attention:

1. The electrical net must be protected with a current leakage safety relay.
2. The electrical network must comply with local rules or regulations.
3. The autoclave must be connected to a properly grounded outlet

2.7 *Waste Water Disposal*

Caution !



Waste-water may be brought into the public water piping in accordance with the local rules or requirements. I.e. only non-hazardous liquids may be disposed in public sewage!

2.8 *Environment Emission Information*

- A. The peak sound level generated by the sterilizer is $\ll 78$ / dBA with background noise of 60 dB.
- B. The total heat transmitted by the sterilizer is < 100 W/h for 1730/2340/2540 models and < 150 W/h for 3140/3850/3870 models.

2.9 Dimensions

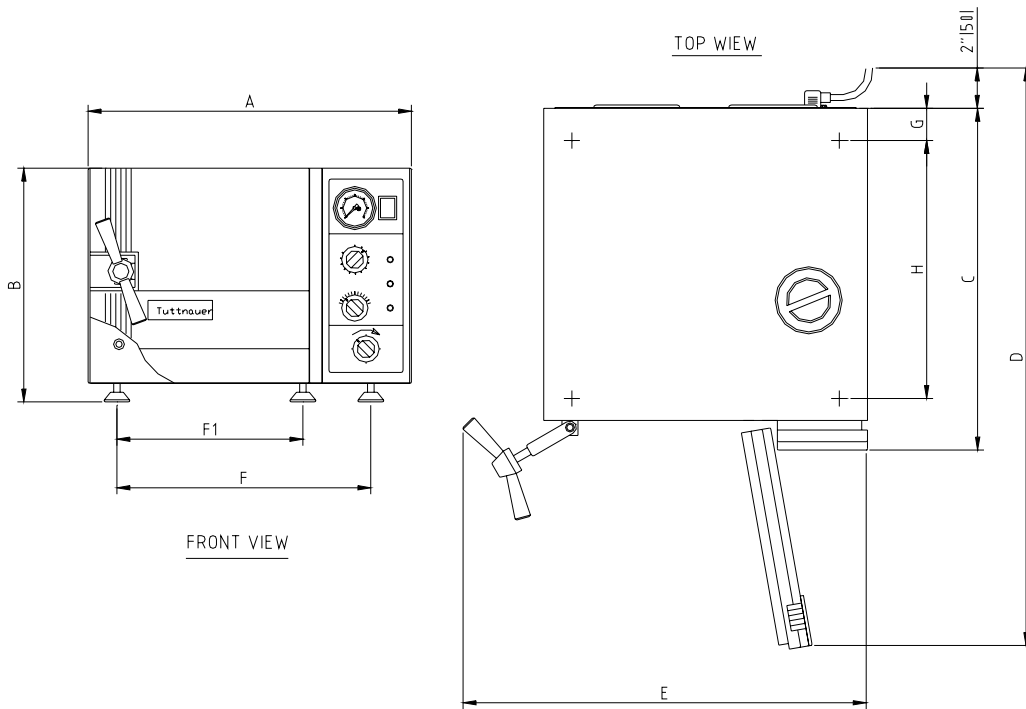

Model	1730		2340		2540		3140		3850		3870		
	M, MK MK-Valueklave		M, MK		M, MK		M		M		M		
	in	mm	in	mm	in	mm	in	mm	in	mm	in	mm	
Overall Dimensions	A	17.4	440	20.0	510	20.0	510	23.2	590	26.0	660	26.0	660
	B	12.0	305	14.4	365	14.4	365	17.7	450	20.7	525	20.7	525
	C	17.9	455	21.5	545	21.5	545	21.9	556	27.5	695	34.5	875
Maximum dimensions (door open)	D	29.5	750	35.8	910	35.8	910	39.0	990	45.5	1155	53.0	1335
	E	22.0	560	25.8	655	25.8	655	29.7	755	32.0	815	32.0	815
Distance between supporting legs F1-front legs F -rear legs	F1	13.7	347	11.8	299	11.8	299	19.2	488	17.7	450	17.7	450
	F	13.4	339	16.6	422	16.6	422	14.6	371	22.2	564	22.2	564
	G	2.0	50	2.0	50	2.0	50	2.0	50	2.0	50	2.0	50
	H	12.4	315	15.8	400	15.8	400	15.2	386	21.8	555	30.5	725
Chamber Diameter		6.7	170	9.1	230	10	254	12.3	312	15.1	384	15.1	384
Chamber Depth		13.4	340	18.5	470	18.7	475	15.4	391	22.8	580	29.9	760

2.10 Technical Specifications

<i>Model</i>	Chamber dimensions DIA x D	Volume of chamber	Tray dimensions W X D X H	No. of trays	No. of standard Cassettes (Optional)		Shipping Weight	Shipping Volume
					<i>Half</i>	<i>full</i>		
1730 M, MK <i>MK-Valueklave</i>	17 x 34 cm (6.7" x 13.4")	7.5 liters. (2 US gal.)	12 x 29.5 x 2 cm (4.7" x 11.6" x 0.8")	3	2	—	24.8 kgs. (54.7 lbs.)	0.18 m ³ (6.35 cu.f.)
2340 M, MK	23 x 47 cm (9" x 18.5")	19 liters. (5 US gal.)	17 x 41.5 x 2cm (6.7" x 16.3" x 0.8")	3	2	2	35.7 kgs. (78.7 lbs.)	0.27m ³ (9.4 cu.f.)
2540 M, MK	25.4 x 47.5cm (10" x 18.7")	23 liters. (6 US gal.)	17 x 41.5 x 2 cm (6.7" x 16.3" x 0.8")	4	3	3	47.8 kgs. (83.3 lbs.)	0.27m ³ (9.4 cu. f.)
3140 M	31.2 x 39.1 (12.3" x 15.4")	34.4 liters (7.8 US gal.)	25.6 x 40.8 x 2.5 cm (10.1" x 16.1" x 1") 19.8 x 40.8 x 2.5 cm (7.8" x 16.1" x 1")	2	4	4	60 kgs (132 lbs.)	0.35 m ³ (12.4 cu.f)
3850 M	38 x 58 cm. (15" x 23")	65 liters. (17US gal)	28 x 50 x 2.5 cm (11" x 20 " x 1") 35 x 50 x 2.5cm (14" x 20 " x 1")	2	—	10	89 kgs. (196 lbs.)	0.63 m ³ (22.2cu.f.)
3870 M	38x76 cm (15" x 30")	84 liters. (22 US gal)	28 x 67 x 2.5cm (11" x 26" x 1") 35 x 67 x 2.5 (14" x 26" x 1")	2	—	15	102 kgs. (225 lbs.)	0.76m ³ (26.8cu.f)

2.11 Electrical Data

<i>Model</i>	<i>1730</i>		<i>2340</i>		<i>2540</i>		<i>3140</i>	<i>3850</i>	<i>3870</i>
	<i>M</i>	<i>MK</i> <i>MK-V</i>	<i>M</i>	<i>MK</i>	<i>M</i>	<i>MK</i>	<i>M</i>	<i>M</i>	<i>M</i>
Total power model 120V	8.8A	11.2A	11.7A	-	11.7A	-	20.0 A	-	-
Total power model 230V	4.6A	5.9A	6.0A	9.6A	6.0A	9.6A	10.4 A	10.4 A	13A
Heaters W	1050	1350	1400	2200	1400	2200	2400	2400	3000
Degree of protection by enclosure					IP31				

2.12 Maximum Load Sizes

<i>Models</i>	<i>Loads</i>	
	<i>lbs</i>	<i>kg</i>
1730	3.3	1.5
2340	7.0	3.2
2540	8.8	4.0
3140	11.0	5.0
3850	13.6	6.0
3870	17.5	8.0

2.13 Symbol Description



Caution! Consult accompanying documents



Caution! Hot Surface.



Caution! Hot steam.



Ground

FRONT VIEW

- | | |
|---------------------------------|---------------------------|
| 1. Front legs | 9. Air trap jet |
| 2. Reservoir water drain valve. | 10. Pressure gauge |
| 3. Door Closing Device | 11. Timer |
| 4. Door Micro-switch | 12. Thermostat (B10) knob |
| 5. Autoclave cover | 13. Multipurpose valve |
| 6. Water reservoir cover | 14. Heat indicator light |
| 7. Water reservoir | 15. Dry indicator light |
| 8. Safety valve | 16. Power indicator light |
| | 17. Main power switch |

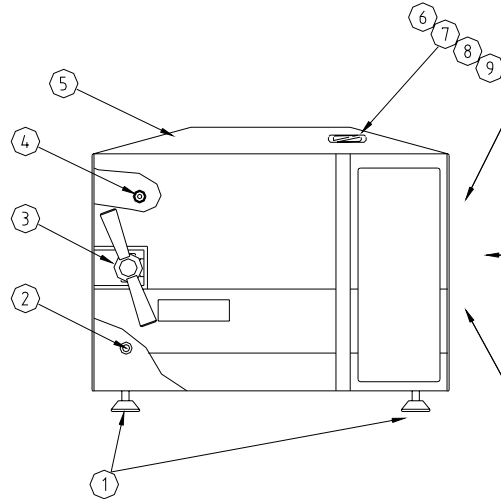

Models 1730 M, MK

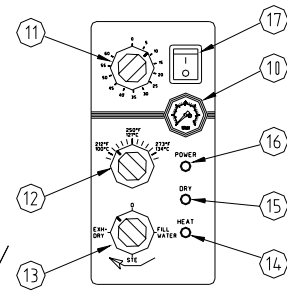

Models 2340/2540 M, MK

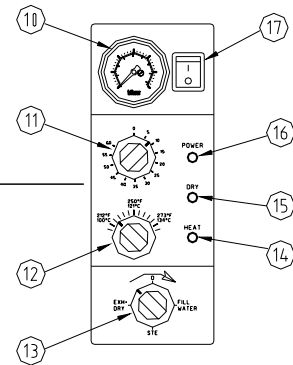

Models 3140/3850/3870 M, MK

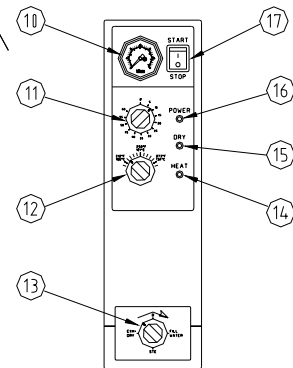

Model 1730 MK Valuelave

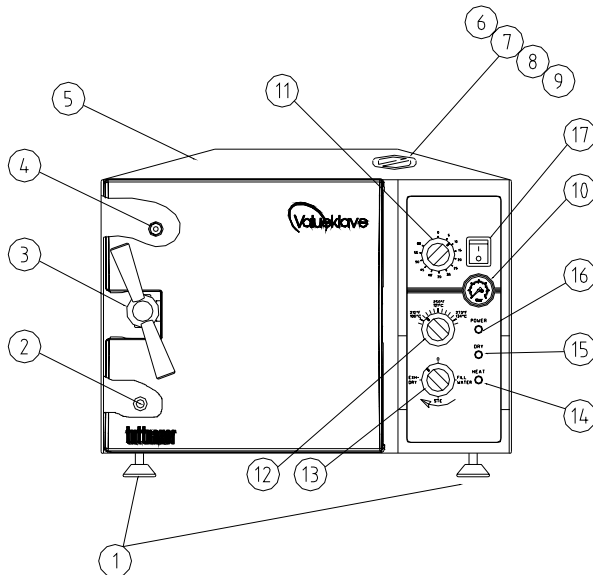

REAR VIEW

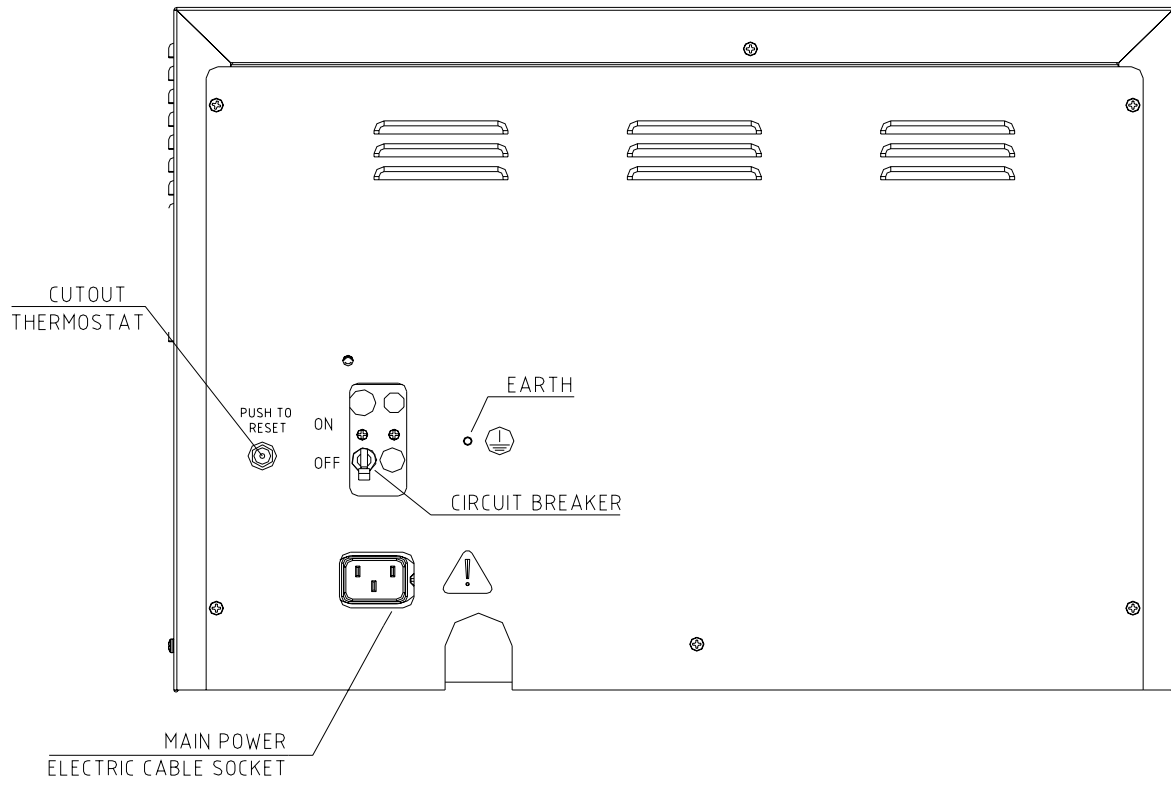

3

DESCRIPTION OF COMPONENTS

The item numbers refer to the front view in the previous page

3.1 Control Panel

Item	Description	Operation	
10.	PRESSURE GAUGE	0-60 psi, (0-4bar) indicates the chamber pressure and includes maximum point indicator.	
11.	TIMER 0-60 min.	Sets the time for sterilization and drying cycles (see section 7 for correct cycle time settings). Note: The power to the heating elements is switched off when the Timer reaches 0 minutes.	
12.	THERMOSTAT	Sets the desired sterilization temperature for each cycle within the range of 212°F - 273°F (100°C - 134°C).”	
13.	MULTI-PURPOSE VALVE	Position	
		1. FILL	Water flows from the water reservoir into the chamber.
		2. STE.	Valve closed to all directions.
		3. EXH.& DRY	Exhausts the steam from the chamber into the water reservoir after the sterilization cycle is finished.
		4. “ 0 ”	Heating elements are disconnected, no cycle is in progress.
14.	HEAT INDICATOR LIGHT	Lights to indicate that the heaters are activated. It will cycle off and on when the temperature reaches the preset valve.	
15.	DRY INDICATOR LIGHT	Lights to indicate that drying cycle is in process.	
16.	POWER INDICATOR LIGHT	Light to indicate that the main switch is on.	
17.	MAIN SWITCH-	Main power switch, which supplies electric power to the autoclave.	

3.2 Other Components

Item	Description	Operation
2.	WATER DRAIN VALVE	Enables the drainage of water from the reservoir.
7.	WATER RESERVOIR	Holds water for sterilization and also serves as a condenser for the hot steam during the exhaust phase.
8.	SAFETY VALVE	Located in the water reservoir. Protects the chamber by releasing any pressure above 40psi (2.7bar). This Safety Valve is required and approved by ASME.
9.	AIR TRAP JET	Located in the water reservoir. Eliminates air during heat up phase to insure correct sterilization temperature is reached. Also prevents air pockets and pockets of cold steam from forming in the chamber.
◆	SAFETY THERMOSTAT	Prevents over-heating during the sterilization and drying stages, will automatically reset itself
◆	CUT-OUT THERMOSTAT	Cuts off the power in case of overheating if the safety thermostat does not operate. This thermostat does not reconnect automatically but must be reset.

4 **INSTALLATION INSTRUCTIONS**



Caution:

The sterilizer must be placed on a rigid and leveled surface. The stand must be able to hold the load of the device and loaded material.



Note:

Make sure while placing the autoclave, to leave space around the machine, to give the technician access to service the machine.

4.1 **Electrical**

The electrical connection should comply with the devices power requirement. It must also comply with local installation and safety rules and regulations. The voltage supplied to the device must comply with the label $\pm 5\%$.

In order to avoid any injury by electrical hazard, it is mandatory for the customer to have installed an earth leakage relay (GFI outlet or circuit breaker) in the electrical circuit to which the autoclave is connected. This relay disconnects all the poles of the electrical power line in case of accidental contact with the autoclave's metal enclosure, by the operator or another person, leading to a dangerous leakage current.

Note: *Keep the back and the right side of the autoclave approximately 1" (25mm) away from the wall to allow for ventilation.*

Connect the power cord to the socket on the rear side of the autoclave; plug it into the supply outlet.

4.2 **Setup**

Proper adjustment of the chamber pitch is one of the most important things you can do for the sterilizer. Proper chamber pitch insures that among other things the sterilizer will have the proper amount of water in the chamber at the beginning of each cycle. Insufficient water in the chamber, at the beginning of the cycle, will cause the unit to over heat and activate one of the safety thermostats. This will occur at some point during the cycle when the water level becomes to low. If on the other hand there is too much water in the chamber this will extend the heating portion of the cycle. Extending the heat up time will shorten the sterilization time causing items to not be sterilized, indicator strips to not change color and spore tests to fail.

For proper setup please follow these setup steps (see drawing below):

- ◆ The autoclave should be turned off and unplugged
- ◆ Make sure the counter is level and sturdy (3)
- ◆ Make sure all the feet are on the autoclave and none have been lost.
- ◆ Make sure the feet are free to move in and out (2)
- ◆ Position the autoclave on the counter
- ◆ Fill the reservoir with distilled water (see sec 7.2)
- ◆ The chamber should be empty of any instruments, trays or leftover water.

- ◆ The chamber pitch now needs to be adjusted
- ◆ Measure to the proper amount of distilled water for the appropriate model unit as listed below (the tolerances on these amounts are +2 oz. and -0 oz)

1730		2340/2540		3140		3850		3870	
10-12 oz	300-350 ml	12-15 oz	350-450 ml	14-16 oz	420-480 ml	20-23 oz	600-690 ml	24-27 oz	720-810 ml.

- ◆ Pour the proper amount of water into the chamber through the front door of the unit (4)
- ◆ This water should cover the bottom of the chamber to within +/- 1/2 inch of the groove in the front. (1)
- ◆ If necessary adjust the front leveling feet, up or down, so that the water lays in the chamber correctly. (2)
- ◆ Once the chamber pitch adjustment is completed, the unit is ready to operate

Note: *It is imperative to have the correct amount of water in the chamber each cycle for proper operation of the autoclave.*

4.3 Lifting and carrying



Caution:

Before moving the autoclave, Make sure that the electric cord is disconnected from the power and there is no pressure in the chamber.

1. Disconnect the power supply cord.
2. Drain the water from the reservoir and vessel.

To avoid injuries, lifting and carrying should be done by two people.

Do not drop this device!

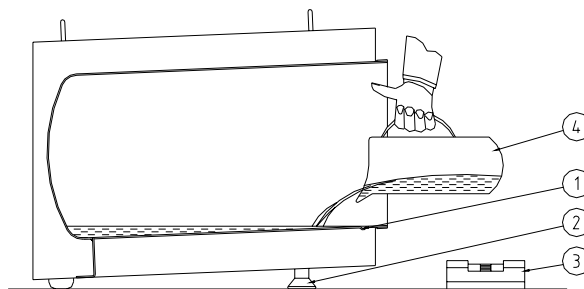

5 **WATER QUALITY**

The distilled or mineral – free water supplied to the autoclave should have the physical characteristics and maximum acceptable level of contaminants indicated in the table below:

Physical characteristics and acceptable contaminants levels in water, for sterilizers

Evaporate residue	≤ 15 mg/l
Silica	≤ 2 mg/l
Iron	≤ 0.2mg/l
Cadmium	≤ 0.005 mg/l
Lead	≤ 0.05 mg/l
Rest of heavy metals	≤ 0.1 mg/l
Chloride	≤ 3 mg/l
Phosphate	≤ 0.5 mg/l
Conductivity	≤ 50 µs/cm
pH	6.5 to 8
Appearance	Colorless, clean, without sediment
Hardness	≤ 0.1 mmol/l (10ppm)

Compliance with the above data should be tested in accordance with acknowledged analytical methods, by an authorized laboratory.

Attention:

We recommend testing the water quality once a month. The use of water for autoclaves that does not comply with the table above may have severe impact on the working life of the sterilizer and can invalidate the manufacturer's guarantee.

6 **PREPARATION BEFORE STERILIZATION**

The purpose of packaging and wrapping items for sterilization is to provide an effective barrier against contamination during storage, once the items have been sterilized.



VERY IMPORTANT!

When sterilizing cotton wool or pads, it is essential to wrap them in paper or cotton bags in order to prevent the multi-purpose valve and the autoclave openings from becoming clogged with remnants of the material.

Packaging and wrapping materials should be approved for use in a steam sterilizer and permit the removal of air and penetration of the steam during the sterilization process.

The basic principle of determining the size, mass and contents of instrument and hollowware packs is that the contents are sterile and dry immediately upon completion of the drying cycle

Instruments to be sterilized must be clean and free from any residual matter, such as debris, blood, pads or any other material. Such substances may cause damage to the instruments themselves or the sterilizer.

1. Clean instruments immediately after use. It is recommended that instruments be ultrasonically cleaned in a Tuttnauer™ **Clean and Simple Ultrasonic** using Tuttnauer™ **Clean and Simple** enzymatic cleaning solution.
2. After ultrasonic cleaning rinse under tap water for 30 seconds and pat dry to remove residual minerals. If your tap water has a high mineral content then rinse a second time in a bath of distilled water and pat dry.
3. Launder textile wraps prior to reuse, but **do not** use bleach.
4. Follow the instrument manufacturer's instructions for cleaning and lubricating instruments.
5. Be sure that instruments of dissimilar metal (stainless steel, carbon steel, etc.) are separated. Carbon steel instruments should be bagged or placed on autoclavable towels and not directly on stainless steel trays. (Mixing will result in the oxidation of these metals).
6. Load items within the boundaries of the tray so that they do not touch the chamber walls, or fall off when the tray is inserted into the autoclave. The chamber walls are very hot, items that come into contact with the wall can be damaged
7. Check the manufacture's instructions as to the proper procedure for sterilizing each item. The instrument manufacture can give specific information on proper sterilization temperature and sterilization time for any item.
8. Place a sterilization indicator in each tray or inside each wrapped pack
9. When using a paper / plastic bag the plastic side should always be down. Use single-use wraps once only and discard after use.
10. Verify that the packaging method is in accordance with good practice approach and the packaging materials are in accordance with the applicable standards (e.g. EN868 series).

11. At least once per week use a biological spore test (*Bacillus Stearothermophilus*) in any load to insure proper sterilization. (**Be aware testing standard may vary**).
12. All instruments **must** be sterilized in an open position. Place instruments with ratchets opened and unlocked or clipped on the first ratchet position. Surfaces that are hidden because the item is in a closed position will not be exposed to the steam and will not be sterilized

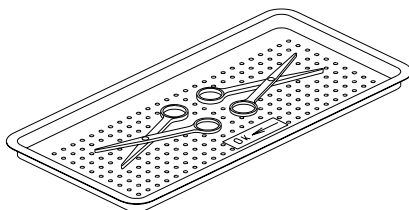

13. Disassemble or sufficiently loosen multiple-part instruments prior to packaging to permit the sterilizing agent to come into contact with all parts of the instrument.
14. Make sure that all instruments remain apart during the sterilization process. Surfaces that are hidden because items are covering other items will not be exposed to the steam and will not be sterilized
15. Items prone to trapping air or moisture, e.g. hollowware, should be tilted on edge. This will allow a minimal resistance to the removal of air or condensate during sterilization and drying.
16. The operator may use racks to allow for adequate separation of packaged instruments.
17. Do not overload the sterilizer trays. Overloading will cause inadequate sterilization and poor drying. Load trays loosely to capacity. Instruments should be loaded one level deep only. See table in section 2 for recommended loading capacities.
18. Tubing should be rinsed after cleaning. When placed in the tray make sure that both ends of the tubing are open and there are no sharp bends or twists
19. Empty canisters should be placed upside-down, in order to prevent accumulation of water.
20. Allow a distance of approximately 1" (2.5 cm) between trays or cassettes to permit steam circulation.
21. Wrapped instruments should be packed in material which will allow steam penetration and promote drying, such as autoclave bag, autoclave paper, or muslin towels.
22. **Do not stack pouches.**

It is recommended that a Tuttnauer™ **Pouch Rack** be used. This will allow the operator to place pouches on their side, which will increase capacity and will allow for better exposure to steam for sterilization and better circulation of air for drying.

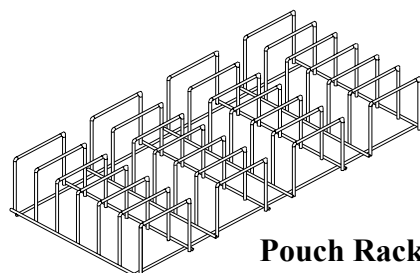

Pouch Rack

23. If spotting is detected on the instruments the first step would be to use an ordinary eraser to remove the spot. If there is no pitting under the spot then the spot was only dirt. Dirt spots on an instrument may be an indication that the autoclave needs to be cleaned or that the instruments were not adequately cleaned or dried. If removal of the spot reveals pitting then the spot was most likely rust. Rust spots on an instrument are not uncommon on inexpensive instruments. It may also be an indication that the instruments were rinsed in tap water with a high content of minerals. These minerals when exposed to high temperature and steam will accelerate the oxidation of the metal. One suggestion would be to final rinse the instruments in distilled water.
24. If the instruments exhibit a discoloration this can be due to the mixing of carbon steel and stainless steel. When these two metals come into contact with each other electrolysis occurs that breaks down the metal. The best solution is to separately wrap the carbon steel to insulate it from other instruments or the trays.

25. Packs

VERY IMPORTANT!



When sterilizing cotton wool or pads, it is essential to wrap them in paper or cotton bags in order to prevent the multi-purpose valve and the autoclave openings from becoming clogged with remnants of the material.

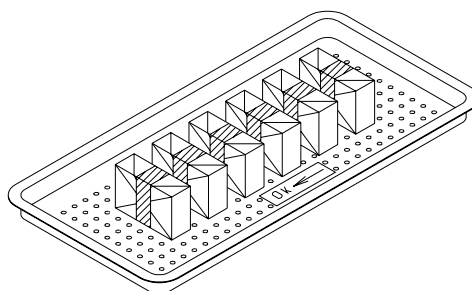

1. Place packs upright on trays, side by side.
2. Packs should not touch the chamber walls.
3. Pack instrument sets in a manner that prevents damage to delicate items.
4. Pack hollowware sets so that all openings face the same direction and so that the contents cannot move inside the pack.
5. Load packs of folded operating room drapes with layers vertical, allowing air to be removed from the packs rapidly.
6. Do not place packs of hollowware and trays of instruments above textile packs or soft goods in order to avoid wetting caused by condensation from items above.
7. Load items packed in flexible packaging materials on edge with paper to laminate, or flat with the plastic surface downwards.

Note: The manufacturer's recommendations shall be observed, concerning the sterilization data for each type of material.

26. Tubing

1. When placing in a tray, make sure that both ends are open, without sharp bends or twists.

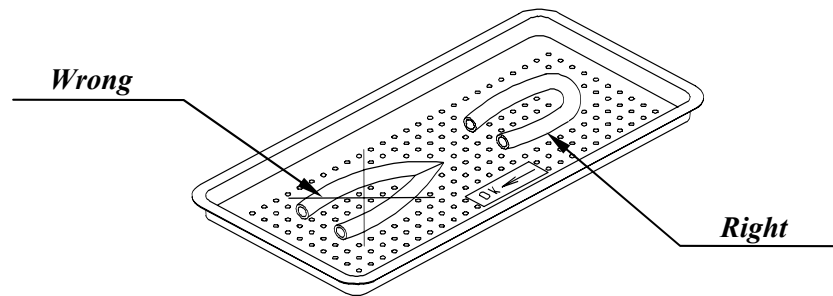

27. Cassettes

1. Instruments may be sterilized in cassettes. The advantage of the cassettes is that the sterilized instruments may remain organized in the cassettes ready for use, while stored in a sterile area.
2. If using models 2340 / 2540 remove the trays and slide the cassettes into the chamber on the rack system.
3. If using models 3850 / 3870 place the cassettes directly on the tray, either lying flat (but no stacking) or on edge.

7

OPERATION



To avoid possible damage, do not leave the autoclave un-attended while in operation.

Make sure the power cord is plugged into the back of the unit and also plugged into a power source.

7.1 Loading and unloading the Device

7.1.1. Safety

Protective equipment and clothes and other safety instructions should be implemented in accordance with local and national regulations and/or rules!

For proper sterilization - Do not overload the chamber. Only autoclavable products shall be used; please refer to the materials or instruments manufacturers instructions for sterilization of unknown materials or instruments.

7.1.2. Loading

Correct loading of the autoclave is essential to successful sterilizing for several reasons. Efficient air removal from the chamber and the load will permit steam penetration and saturation, and allow proper drainage of condensate. Additionally, correct loading will reduce damage to packs and their contents and maximize efficient use of the sterilizer.

For detailed loading instructions, see sec. 6 (Preparation before sterilization)

7.1.3. Unloading

On completion of the cycle, the load shall be immediately removed from the sterilizer and a visual inspection made to ascertain that the load is dry, and that sterilizing indicators have made the required color change.

7.2 Fill the Water Reservoir

7.2.1. Ensure that the drain valve is in a CLOSED position.

7.2.2. Remove the water reservoir cover.

7.2.3. Pour distilled water into the reservoir through the opening on top of the autoclave, until it reaches the base of the safety valve holder. **Under no circumstances fill any higher than the base of the safety valve holder.**

7.2.4. For proper operation make sure the water level is above the coils of the cooling coil

Caution:

Under no circumstance should water be filled above the safety valve holder.

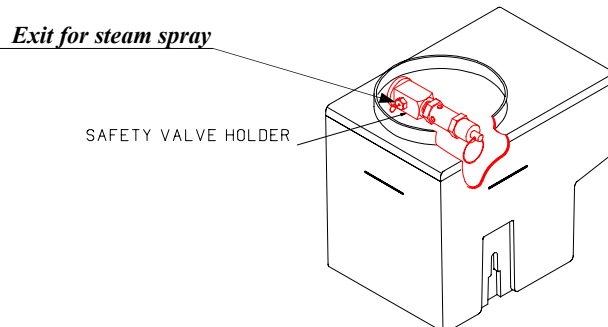

- 7.2.5. **USE DISTILLED WATER ONLY.** Use water-having characteristics as per table in sec 5. The impurities in tap water will create the need for more frequent cleaning and maintenance, in addition they will accumulate and block the hole of the **Air Jet**. This will prevent the temperature in the chamber from rising properly. **This will cause the unit to abort its cycle, spore tests to fail and indicator strips not to change color.** It is essential from time to time during heating and sterilization phases that a spray of steam should escape, from the Air Jet, causing a hissing sound. If no escaping steam is evident or no hissing sound heard then follow the instructions in sec 8.3 for cleaning the **Air Jet**.

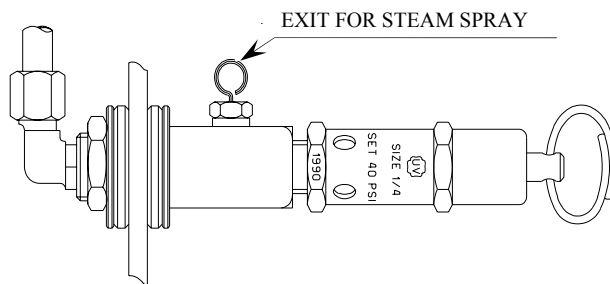

Caution:

Daily before operation, check the water level in the reservoir and add water when required. Once a week or after 20 cycles (the shorter period) replace the water in the reservoir.

- 7.3. Move the Start / Stop rocker switch, located on the front panel, to the START position. The green Power Light will turn on, indicating that power is ready to be supplied to the Heating Elements.
- 7.4. Turn the red tracking needle on the pressure gauge, counterclockwise, to 0 psi. This will indicate the highest pressure reached during the cycle.
- 7.5. Open the front door of the autoclave and set the Multi-purpose valve knob to the FILL position.
- 7.5.1. The water will now flow into the chamber.
- 7.5.2. The water should cover the bottom of the chamber up to the groove in the front. This amount of water should be in accordance with the table in sec 4.2
- 7.5.3. When the water reaches the mark at the front of the autoclave set the multi-purpose valve knob to the STE. (sterilize) position.

Note:

When used for the first time, the multi-purpose valve requires slight effort, but with use it will turn smoothly and easily.

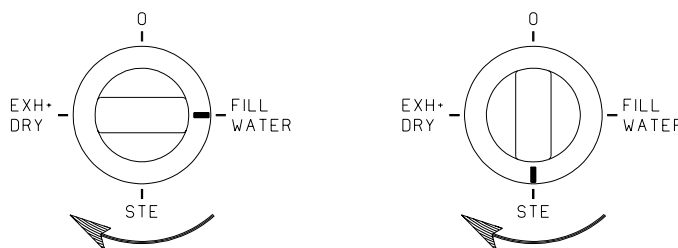

Warning

The Multi-purpose valve knob should be turned in a clock-wise direction only!

- 7.6. Load the autoclave. See section “Preparation for Sterilization” for information on proper loading.

- 7.7. Shut the door, move the Door Closing Device into position and tighten, making sure that the Door Switch is activated.

NOTE:

Due to the inherent elasticity of the door gasket, it is important to tighten the door bolt until "hand tight". Do not over - tighten the bolt as this may result in damage to the gasket.



Should the autoclave fail to reach the sterilizing temperature/pressure, always check first that the door is fully sealed. If not, then tighten the door bolt further, as described above, until completely sealed.

- 7.8. Turn the Thermostat knob to the desired sterilization temperature.
Note: *This autoclave is designed according to all international standards, which allows the temperature to raise 4°F (2°C) over the working temperature.*

Sterilization Time Table

<i>Material</i>	<i>STE. TEMP</i>	<i>TOTAL TIME</i> (from start to finish)				<i>Models</i>
		<i>MK</i>		<i>M</i>		
		Cold Start	Hot Start	Cold Start	Hot Start	
a. Unwrapped instruments, open glass or metal containers and any other items where such temperature is suitable	273°F (134°C)	15min.	12min.	30min. 35min.	20min. 25min.	1730 2340 2540 3140, 3850, 3870
Single Instruments		12min.	9min.			
b. Wrapped instruments, standard cassettes, rubber tubing and any other items where such temperature is suitable.	273°F (134°C)	20min	15min.	40min. 45min.	30min. 35min.	1730 2340, 2540 3140, 3850, 3870
c. Packs and any other items where such temp. is suitable.	273°F (134°C)	25min.	20min.	45min.	35min.	All models
d. Any items where a lower sterilization temp is required	250°F (121°C)	30min.	25min.	60min.	50min.	All models

Note: The table shows different times for M (Standard Manual) & MK (Kwiklave Manual) units as well as for hot and cold starts.

Make sure you are using the correct times for your model machine.

A hot start is any cycle that is begun within 1 hour of a previous cycle ending (including drying time).

Note: These sterilization times are based on the unit being supplied the correct voltage, as indicated on the Technical Label attached to the outer cabinet. If the voltage supplied is substantially less than the indicated voltage, additional time must be added to each cycle.

- 7.9. Set the Timer to the desired sterilization cycle time according to the Sterilization Time Table.
- 7.9.1. The Heat Light will come on, indicating that power is being supplied to the Heating Elements and remain on until the correct sterilization pressure is achieved.
- 7.9.2. Once the correct pressure is reached the Heat Light will cycle on and off, indicating that the Heating Elements are turning on and off to maintain the correct sterilization pressure.
- 7.9.3. When the Timer reaches 0 min, the Heating Elements are turned off and a buzzer will sound indicating that the sterilization cycle is complete.
- 7.10. If unwrapped instruments were sterilized and no drying is required then follow these steps.
- 7.10.1. Once the Timer has reached 0 min turn the Multi-purpose valve knob, promptly, to the Exhaust / Dry position. This will allow the steam and leftover water to return to the reservoir
- 7.10.2. When the white needle on the pressure gauge has reached 0 psi the door can be opened.
- 7.10.3. Unscrew the Door Closing Devise, move it to the side and open the door to remove the instruments.
- 7.10.4. Now turn the Multi-purpose valve knob to the “0” or off position.

Note: The sterility of instruments processed in unwrapped cycles cannot be maintained if exposed to a non-sterile environment.

- 7.11. If wrapped instruments were sterilized and drying is required then follow these steps.
- 7.11.1. Once the Timer has reached 0 min then turn the Multi-purpose valve knob, promptly, to the Exhaust / Dry position. This will allow the steam and leftover water to return to the reservoir. Do not allow the pressure to drop below 10 psi. This will cause water to remain in the bottom of the chamber even after the Multi-purpose valve has been turned to Exh / Dry. Resetting the Timer for drying will only be heating up this water and not drying the instruments.
If the pressure has dropped below 10 psi then leave the unit in the STE position, leave the door closed and locked. Now reset the Timer for 10 minutes.



When the Timer reaches 0 min the pressure should be above 10 psi (if not add 5 more minutes to the Timer) now turn the Multi-purpose valve to the Exh / Dry position. This will insure that all the water has been returned to the reservoir.

Note: The sooner the Multi-purpose valve is turned to Exh / Dry at the end of the sterilization cycle the more effective and efficient will be the drying.

- 7.11.2. When the white needle on the pressure gauge has reached 0 psi the door can be opened.
- 7.11.3. Unscrew the Door Closing Devise as far as it will go, **but do not move it to the side**, this will allow the door to open about ¾ of an inch.

- 7.11.4. Leave the Multi-purpose valve knob in the Exhaust / Dry position.
- 7.11.5. Now reset the Timer for drying, 20 – 30 minutes, the Dry Light will come on indicating that Drying is active and the Heating Elements are back on.
- 7.11.6. When the Timer reaches 0 min the drying is complete and the Dry Light and Heating Elements will turn off.
- 7.11.7. Now turn the Multi-purpose valve to the off position “0” and open the door to remove the instruments.

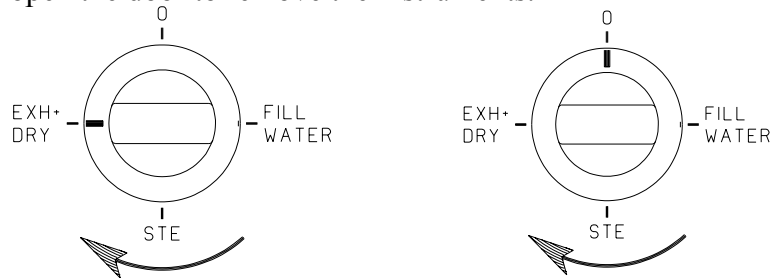

Warning

Multi-purpose valve knob should be turned in a clockwise direction only.

- 7.12. At the end of the day turn the Start / Stop rocker switch to the STOP position.

8 SERVICE AND MAINTENANCE INSTRUCTIONS

8.1 Preventive and Scheduled Maintenance



The maintenance operations described in this chapter need to be followed as indicated to keep the device in good working condition.

The instructions that follow can easily be carried out by the office personnel and do not require a service technician.

Should the need arise technical assistance or a service technician can be requested by either calling your dealer or Tuttnauer USA.

8.1.1 Daily

Clean door gasket with a mild detergent, water and a soft cloth or sponge. The gasket should be clean and smooth.

8.1.2 Weekly

1. **ONCE PER WEEK**, clean the air jet. To ensure that the temperature inside the chamber rises properly it is necessary to keep the air jet clean. A dirty air jet will prevent indicator strips from changing color and cause spore tests to fail. See sec. 8.3.
2. Once per week clean and descale the chamber, copper tubes and the reservoir using Chamber Brite (see sec. 9).



Caution

Do not use steel wool, steel brush or bleach as this can damage the chamber and trays!

3. Take out the tray holder and trays. Clean the tray holder and trays with detergent or a non-abrasive stainless steel cleaner and water, using a cloth or sponge. Rinse the tray holder and trays immediately with water to avoid staining the metal.
4. Put a few drops of oil on the 2 door pins and door tightening bolt screw shaft and bearing.
5. Clean the outer parts of the autoclave with a soft cloth

8.1.3 Periodically

1. Once every month clean and check the safety valve(see sec. 8.5).
2. Replace the door gasket every 12 months, or as needed (see sec. 8.4).
3. Once a year inspect the locking device for excessive wear.

8.2 *Draining the Reservoir*



Caution

Before starting, ensure that the electric cord is disconnected and there is no pressure in the autoclave.

The drain valve is located on the front left side of the autoclave after the door is opened. The function of the drain valve is to drain the water reservoir.

1. Connect the silicone hose, supplied with the autoclave, to drain into a bucket.
2. Turn drain valve counter clockwise to the open position.
3. Fully drain the reservoir
4. With a quart of tap water flush out the reservoir
5. Turn drain valve clockwise to the close position.
6. Connect the electric cord to power source.
7. Fill the reservoir with distilled water to just below the safety valve (see sec 7.2)
8. Turn on the main power switch.
9. The autoclave is now ready for use.

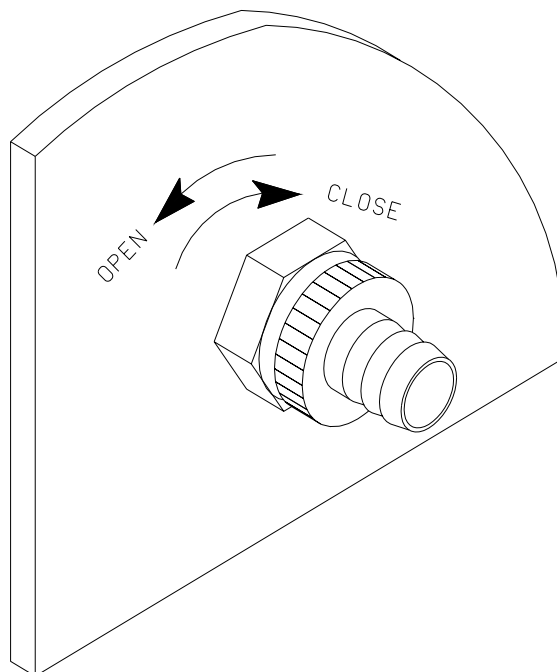

8.3 *Cleaning Air Jet*

(Located in the water reservoir.)



A dirty air jet is the number one cause of failed spore tests

The elimination of air from the sterilization chamber during heat up is **critical** to the proper operation of the autoclave. Failure of the air removal system will be responsible for incomplete sterilization, indicator strips that do not turn and failed spore tests.

The air jet consists of a small orifice with a clean out wire inserted in it (wire is permanently installed and will not come out). It is required that the air jet be cleaned once per week or more often if necessary, to remove any accumulated dirt and debris.

It is preferred to clean the air jet when the unit is running a cycle and under pressure. This is so that any loosened debris will be blown away, however, it can be done while the unit is idle.

1. Remove the water reservoir cover.
2. Clean the hole of the jet by manipulating the air trap wire back and forth 10 times

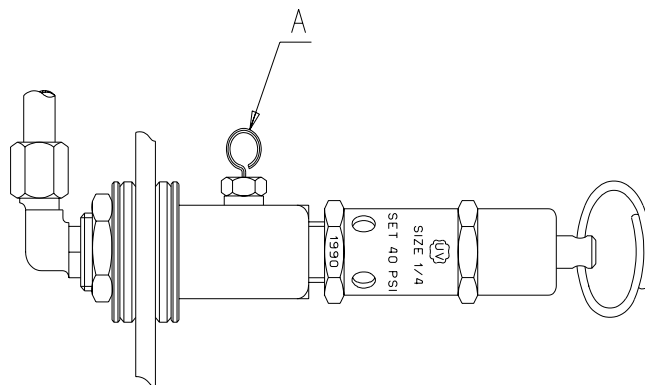

It is important to clean the hole of the air trap, as described at point 2 before starting operation of the autoclave, for the first time.

8.4 *Replacing the Door Gasket*

Pull off the gasket from the door groove. Install the new gasket as described in drawings 1, 2 and 3 below.

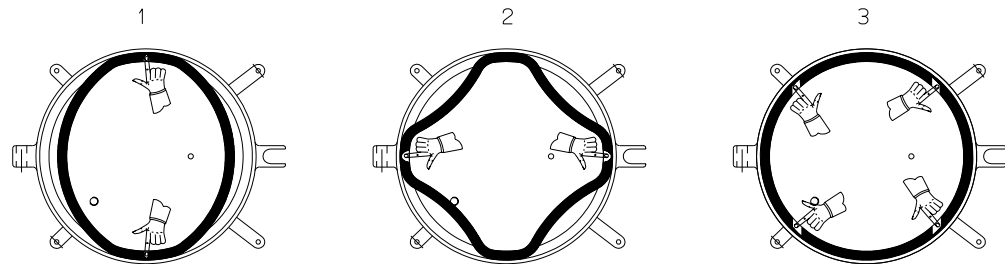

Caution!

This gasket is designed with a trapezoidal cross section. The gasket should be placed with the widest side towards the door.

8.5 *Checking the Safety Valve*

(Located in the water reservoir)

In order to prevent the safety valve from becoming blocked, it is necessary to allow the steam pressure to escape through the valve. This procedure should be done every month as follows:

1. Run a sterilization cycle with a sterilization temperature of 273°F according to the manual.
2. Allow a pressure of approximately 30 psi (260 kpa) to build up in the chamber.
3. Turn the timer back to 0 minutes
4. Remove water reservoir cover



Caution!

This next step will expose you to HOT STEAM



Caution!

To avoid being burned, by hot steam, do not place your face over the safety valve.

5. Pull the ring of the safety valve using a tool, i.e. screwdriver, hook etc and open the safety valve for 2 seconds then release. Be careful not to burn your hands.
6. Verify that the valve releases steam and closes immediately.
7. If the safety valve is stuck in the ‘open” position, let the pressure decrease to zero (atmospheric pressure).
8. After the pressure in the chamber decrease to zero, pull the valve ring to release the valve.
9. Repeat operations 1 to 6.
10. If the valve is stuck again in the open position, call for service.
11. After a successful check turn the multi-purpose valve to the Exh/Dry position.
12. Wait until the pressure decreases to zero, only then can the door be opened.

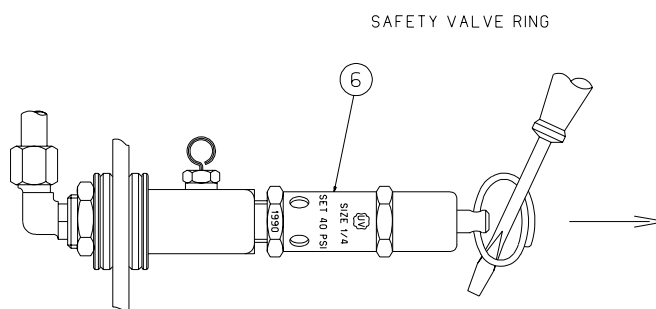

8.6 *Unclogging the multi-Purpose Valve or Fill piping.*

1. Pour distilled water into the chamber, according to quantities mentioned in para. 4 (*Installation Instructions*).
2. Close the door.
3. Turn the multi-purpose valve to STE. position.
4. Move the main switch to the START position.
5. Turn the Thermostat knob to 273 °F (134 °C).
6. Turn the Timer knob to 20 minutes.
7. After the timer has reached “0” turn the multi-purpose valve (clockwise) to the FILL position, do not stop at any other position.

In most cases, the pressure pushes the obstructing substance out, and the steam exhausts into the water reservoir.

8. When the pressure gauge reaches 0, turn the multi-purpose valve to the OFF position, and the main switch to STOP.
9. Open the door.
10. Replace the water in the water reservoir.

The autoclave is ready for the next cycle.

11. If this procedure does not clear up the clogging, then a technician will be required to replace the multi-purpose valve or clear the piping.

“VERY IMPORTANT!



When sterilizing cotton wool or pads, it is essential to wrap them in paper or cotton bags in order to prevent the multi-purpose valve and the autoclave openings from becoming clogged with remnants of the material.

9 **CLEANING TABLE TOP AUTOCLAVES WITH CHAMBER BRITE™**

CHAMBER BRITE™ is a cleaning and descaling agent designed specifically for the cleaning and removal of water deposits, oxides and other sediments that are found in steam sterilizers. The material is a combination of acidic salts and additional cleaning materials.

Chamber Brite™ autoclave cleaner has been formulated specifically to be a fast, powerful and easy to use cleaner for steam sterilizers.”

If the autoclave is not cleaned regularly dirt and debris will build up and clog the tubing and valves. This dirt can also be transmitted to the instruments during sterilization. In addition a layer of dirt on the stainless steel chamber traps moisture against the metal and will lead to the chamber becoming porous and failing.”

“It is recommended that your autoclave be cleaned with chamber Brite once per week”



Caution!

NEVER use bleach, steel wool, a steel brush or anything abrasive to scrub or clean the chamber.

Cleaning Procedure

1. Important – all steps in this procedure must be completed without interruption.
2. When the autoclave chamber is cold, remove instruments and trays from the autoclave.
3. Open the door and spread the contents of a packet in a straight even line along the bottom of the chamber, from back to front.
4. Start a sterilization cycle* with water and No Drying Cycle according to the manufacturers instructions. When the cycle is finished exhaust the unit.
5. At the end of the exhaust cycle drain the water the reservoir.
6. Fill the water reservoir with distilled water.
7. Repeat a sterilization cycle without Chamber Brite™ powder, to remove any excessive dirt in the pipes. Start a sterilization cycle* with water and No Drying Cycle according to the manufacturers instructions. When the cycle is finished exhaust the unit
8. At the end of the exhaust cycle drain the water from the reservoir.
9. Turn the autoclave off and allow chamber to cool.



10. Remove the tray holder; wipe the interior of the chamber with a damp cloth.
11. Fill the reservoir with distilled water only.
12. Wipe the tray holder with a damp cloth and return it to the chamber.
13. Turn fill knob to fill position and allow a small amount of water (2-4 ounces) to fill chamber. Remove water from chamber.
14. The instrument is ready to use.

IMPORTANT:

DO NOT sterilize instruments during the cleaning process!!!

CAUTION:

Keep out of reach of children. Contains mildly acidic ingredients. Avoid contact with the skin, eyes or clothing. Wash hands well after touching the powder, in the case of eye contact flush with continuous running water for at least 15 minutes. If irritation persists get medical attention. If accidentally swallowed, do not induce vomiting, drink large amounts of water and obtain medical attention. MSDS available upon request.

For models 1730, 2340, 2540 use one packet of CHAMBER BRITE™.

For models 3140, 3850, 3870 use two packets of CHAMBER BRITE™.

Clean every 20 cycles or as needed.

- * Total cycle time for cleaning Tuttnauer “M” series is 30 minutes at 273°F (134°C). Total cycle time for cleaning Tuttnauer “MK” series is 15 minutes at 273°F (134°C). All cycles referenced are from a cold start.

10 TROUBLESHOOTING

This troubleshooting section is for use by the Operator of the autoclave. If a problem develops that is not covered in this section then a qualified technician needs to be called. Please call your dealer or Tuttnauer USA Co.

<i>Symptom</i>	<i>Possible cause check-up and tests</i>	<i>Corrections</i>
1. Power indicator light does not light up when the Start / Stop switch is in the start position.	<p>1.1 the unit is not plugged in or the wall outlet has no power</p> <p>1.2 Circuit breaker is tripped</p> <p>1.3 Cut out thermostat is tripped</p> <p>1.4 Turn the multi-purpose valve to the “Exh/Dry” position and set the timer to 15 minutes. If the “Dry” light is on then the “Power” light is burned out. When finished turn the timer back to 0 minutes</p> <p>1.5 If the “Dry” light does not come on then there is an internal electrical problem.</p>	<p>1.1 Make sure the power cord is plugged into the wall outlet and the back of the unit or restore power to the wall outlet.</p> <p>1.2 Reset the circuit breaker.</p> <p>1.3 Reset the cut out thermostat.</p> <p>1.4 Have a technician replace the “Power” light.</p> <p>1.5 Have a technician check out the unit.</p>
2. Heat indicator light does not light up at the beginning of the sterile cycle. The Power light is on and the unit <u>does</u> heat up.	<p>2.1 The “Heat” light is burned out.</p>	<p>2.1 Have a technician replace the “Heat” light.</p>
3. Heat indicator light does not light up at the beginning of the sterile cycle. The Power light is on and the unit does <u>NOT</u> heat up.	<p>3.1 the multi-purpose valve is not in the STE position.</p> <p>3.2 the door is not closed tightly.</p> <p>3.3 The door switch activator is missing or not adjusted correctly.</p> <p>3.4 The timer is off.</p> <p>3.5 There is an internal problem.</p>	<p>3.1 Turn the multi-purpose valve to the STE position</p> <p>3.2 Close the door tightly</p> <p>3.3 Replace or readjust the door switch activator. When adjusting – unscrew the by ¼ turn until the door microswitch is pushed in when the door is closed.</p> <p>3.4 Turn the timer on</p> <p>3.5 Have a technician check out the unit.</p>

<i>Symptom</i>	<i>Possible cause check-up and tests</i>	<i>Corrections</i>
4. Dry indicator light does not light up at the beginning of the dry cycle. The Power light is on and the unit <u>does</u> heat up.	4.1 The “Dry” light is burned out.	4.1 Have a technician replace the “Dry” light.
5. Dry indicator light does not light up at the beginning of the dry cycle. The Power light is on and the unit does <u>NOT</u> heat up.	5.1 The multi-purpose valve is not in the DRY position. 5.2 The timer is off. 5.3 There is an internal problem.	5.1 Turn the multi-purpose valve to the DRY position. 5.2 Turn the timer on. 5.3 Have a technician check out the unit.
6. Water does not enter the Chamber when the multi-purpose valve is in the FILL position.	6.1 There is no water in the reservoir. 6.2 The multi-purpose valve is clogged. 6.3 The fill piping is clogged.	6.1 Fill the reservoir with distilled water. 6.2 Follow the instructions in para 8.6 to unclog the valve. 6.3 Follow the instructions in para 8.6 to unclog the piping.
7. Spore tests are failing or indicator strips are not changing color according to instructions of indicator's manufacturer.	7.1 Air jet is clogged. 7.2 Maybe over loaded. 7.3 The load may be to densely packed. 7.4 Sterilization time may not be correct. 7.5 Unit not reaching the correct sterilization pressure reading on the gauge.	7.1 Clean the air jet see para 8.3 7.2 Adjust loading according to "Maximum Load Sizes" table in sec. 2. 7.3 Items to be sterilized should be separated and not stacked. See preparations for sterilization para. 6. A Tuttnauer Pouch Rack is recommended 7.4 Check table para 7. 7.5 See para. 10.9 “unit does not reach the proper operating pressure”.

<i>Symptom</i>	<i>Possible cause check-up and tests</i>	<i>Corrections</i>
8. Wrapped or bagged items do not dry. See also section 10.32 and section 8.8.	<p>8.1 The unit is not being vented immediately after the sterile cycle.</p> <p>8.2 Units maybe over loaded.</p> <p>8.3 The load may be to densely packed.</p> <p>8.4 Units may not be heating properly.</p>	<p>8.1 Once the timer rings at the end of the sterile cycle immediately turn the multi-purpose valve to the “Exh / Dry” position. Once venting is complete start the drying cycle.</p> <p>8.2 Adjust loading according to "Maximum Load Sizes" table in sec. 2.</p> <p>8.3 Items to be sterilized should be separated and not stacked. See preparations for sterilization para. 6. A Tuttnauer Pouch Rack is recommended.</p> <p>8.4 Have a technician check the unit.</p>
9. Unit does not reach the proper operating pressure.	<p>9.1 Unit is not getting the correct voltage</p> <p>9.2 Chamber was not filled with the correct amount of water</p> <p>9.3 Door gasket is leaking steam</p> <p>9.4 Steam is leaking at the closing device</p> <p>9.5 Safety Valve is leaking</p> <p>9.6 Items being sterilized are absorbing all available steam (cloth towels or gowns)</p> <p>9.7 Heat light goes out before correct pressure is reached</p> <p>9.8 One or more of the heating elements is bad.</p>	<p>9.1 Check table 2.6 for correct operating voltages.</p> <p>9.2 Check section 7 for correct operating procedures.</p> <p>9.3 Tighten the door more, if leaking persists then replace the door gasket.</p> <p>9.4 Door bellows is leaking, have a technician replace the bellows.</p> <p>9.5 Follow procedure in section 8.5 if leaking persists have technician replace the Safety valve.</p> <p>9.6 Sterilize fewer towels or gowns or adjust the front of the unit higher to allow more water into the chamber. See installation instructions section 4.2.</p> <p>9.7 Unit may be out of calibration or there is an internal steam leak. Have a technician check the unit</p> <p>9.8 Have a technician check the unit.</p>

<i>Symptom</i>	<i>Possible cause check-up and tests</i>	<i>Corrections</i>
10. Items in the chamber are burning or melting.	<p>10.1 Chamber was not filled with the correct amount of water.</p> <p>10.2 Items are lying up against the chamber.</p> <p>10.3 The sterilization time is set too high.</p> <p>10.4 Items being sterilized are absorbing all available steam (cloth towels or gowns).</p> <p>10.5 Door gasket is leaking steam.</p> <p>10.6 Steam is leaking at the closing device.</p> <p>10.7 Safety Valve is leaking.</p> <p>10.8 There is an internal steam leak or electrical problem.</p>	<p>10.1 Check section 7 for correct operating procedures.</p> <p>10.2 Make sure no items are touching the walls of the chamber.</p> <p>10.3 Set the sterilization time according to the table in section 7.</p> <p>10.4 Sterilize fewer towels or gowns or adjust the front of the unit higher to allow more water into the chamber. See installation instructions section 4.2.</p> <p>10.5 Tighten the door more, if leaking persists then replace the door gasket.</p> <p>10.6 Door bellows is leaking, have a technician replace the bellows.</p> <p>10.7 Follow procedure in section 8.5 if leaking persists have technician replace the Safety valve.</p> <p>10.8 Have a technician check the machine.</p>
11. Closing device does not open when pressure gauge reads 0 psi.	11.1 Door bellow locking pin is trapped.	11.1 Follow instruction in section 10.31
12. Closing device is hard to close.	12.1 Closing device needs oil.	12.1 Apply 1 or 2 drops of 3 in 1 oil or some white lithium grease to the screw and bearing of the closing device see sec 8.1.2.4.

<i>Symptom</i>	<i>Possible cause check-up and tests</i>	<i>Corrections</i>
13. Water is left in the bottom of the chamber at the end of sterilization.	<p>13.1 Water level too high in the reservoir.</p> <p>13.2 Waiting too long to exhaust after sterilization is complete.</p>	<p>13.1 Do not fill above the safety valve. See sec 7.2.</p> <p>13.2 If unwrapped instruments are being sterilized this is not a problem. For wrapped instruments see sec 7.1.1.</p>
14. Water spills on the floor when the door is open.	14.1 Leaving the multi-purpose valve in the “Exh/Dry” position while leaving the door closed and having a cooling coil that is miss positioned in the reservoir.	14.1 Once the chamber is finished venting open the door right a way. Also, straighten the cooling coil in the reservoir. The open end of the cooling coil should not be below the water line.
15. Cut out thermostat trips.	<p>15.1 The unit has detected an overheating condition do to too little water in the chamber caused by either:</p> <p>a) Incorrectly filling the chamber at the beginning of the cycle</p> <p>b) A leaking door seal.</p> <p>c) A leaking safety valve.</p> <p>d) Absorbent material being sterilized.</p> <p>e) An internal steam leak.</p>	<p>15.1 Correct the cause and reset the Cut out thermostat, if the problem persists have a technician check the machine.</p> <p>a) Check section 7 for correct operating procedures.</p> <p>b) Tighten the door more, if leaking persists then replace the door gasket.</p> <p>c) Follow procedure in section 8.5 if leaking persists have technician replace the Safety valve.</p> <p>d) Sterilize fewer towels or gowns or adjust the front of the unit higher to allow more water into the chamber. See installation instructions section 4.2.</p> <p>e) Have a technician check the machine.</p>
16. Circuit breaker trips.	16.1 A power surge or spike.	16.1 Reset the red lever of the circuit breaker to the up position. If the problem persists have a technician check the unit.

<i>Symptom</i>	<i>Possible cause check-up and tests</i>	<i>Corrections</i>
17. Reservoir does not drain	17.1 Drain valve is clogged.	17.1 Open drain valve completely and blow compressed air into the valve. This should blow the clog back into the reservoir where it can be removed. Cover the reservoir opening to avoid splatter.
18. Drain valve is leaking	18.1 Debris is stopping the valve from seating properly.	18.1 Open drain valve completely and blow compressed air into the valve. This should blow the clog back into the reservoir where it can be removed. Cover the reservoir opening to avoid splatter.
	18.2 Drain valve o-rings are worn.	18.2 Have a technician replace the o-rings.
19. Chamber is black or dirty looking	19.1 Unit has not been cleaned recently.	19.1 Follow cleaning instructions using Chamber Brite section 9.
20. Chamber has a water mark along bottom	20.1 Not using distilled water.	20.1 Use 100% steam distilled water.
	20.2 Unit has not been clean recently.	20.2 Follow cleaning instructions using Chamber Brite section 9.
21. Steam escaping from the closing device area.	21.1 The door bellows is leaking.	21.1 Have a technician replace the door bellows.
22. Steam leaking from the door seal.	22.1 Door may not be tightened down enough.	22.1 Tighten the door more.
	22.2 Door gasket may be worn or cracked.	22.2 Replace the door gasket (see sec. 8.4.
23. Multi-purpose valve turns backwards.	23.1 The internal spring in the multi-purpose valve has broken.	23.1 Have a technician replace the multi-purpose valve.

<i>Symptom</i>	<i>Possible cause check-up and tests</i>	<i>Corrections</i>
24. Multi-purpose valve does not turn.	24.1 Poor maintenance will result in the multi-purpose valve binding.	24.1 Have a technician replace the multi-purpose valve.
25. Red tracking needle on pressure gauge is hard to set.	25.1 No lubrication on the needle shaft. 25.2 Internal spring is too tight.	25.1 Place one drop of oil between the silver knob and the glass of the gauge. Turn the knob back and forth to work the oil onto the internal shaft. 25.2 Use a small screw driver to adjust the small screw in the center of the silver knob.
26. Timer does not time down.	26.1 Internal gearing has worn down.	26.1 Have a technician replace the timer.
27. Timer bell does not ring.	27.1 The hammer on the timer bell has broken off. 27.2 Timer was not turned far enough to set hammer	27.1 Have a technician replace the timer. 27.2 Timer must be turned past 10 minutes to set hammer
28. Safety valve is leaking.	28.1 Debris has lodged in the seat of the safety valve.	28.1 Follow the instructions in sec 8.5.
29. Instruments are rusting.	29.1 The first step is to determine if it is rust or dirt.	29.1 Follow instructions in sec 6.23.
30. Door will not open, closing device is open.	30.1 Unit was left to cool with the door closed and a vacuum developed.	30.1 Make sure pressure gauge reads 0 psi, and then pull on the ring of the safety valve. This will relieve the vacuum in the chamber.

<i>Symptom</i>	<i>Possible cause check-up and tests</i>	<i>Corrections</i>
<p>31. Door handle cannot be turned counter-clockwise for the door to be opened and there be no pressure in the.</p>	<p>31.1 Locking pin is trapped.</p>	<p>31.1</p> <ol style="list-style-type: none"> 1. a. Turn the Multi-purpose valve to EXH. & DRY. b. Turn the handle of the Door Closing Device $\frac{1}{4}$ of a turn in the <u>clockwise</u> (closing direction). The pin will be released, enabling the operator to open the door. <ol style="list-style-type: none"> 2. If this does not correct the problem then a Technician will need to be called
<p>32. Wrapped or bagged instruments are not drying properly (see also sec 7.11).</p>	<p>32.1 Bagged instruments are placed too close to each other.</p> <p>32.2 Cycle ending has not been performed correctly.</p>	<p>32.1</p> <ol style="list-style-type: none"> a. A Tuttnauer Pouch Rack is recommended to provide proper spacing of bagged instruments. This will allow for better exposed to steam for sterilization and better circulation of air for drying. b. If a Pouch Rack is not used them make sure the instruments on the tray are only one level deep and that the paper / plastic bags are plastic side down. <p>32.2 End cycle according to para. 7.</p>

TRAY HANDLE CMT240-0001
For 1730, 2340, 2450 models only

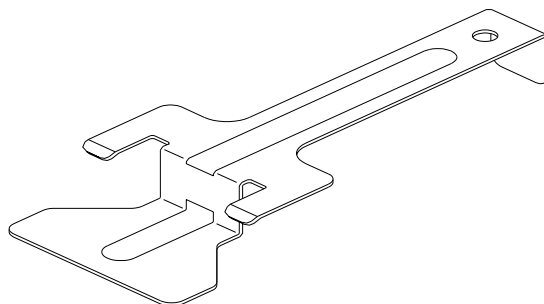

POUCH RACK

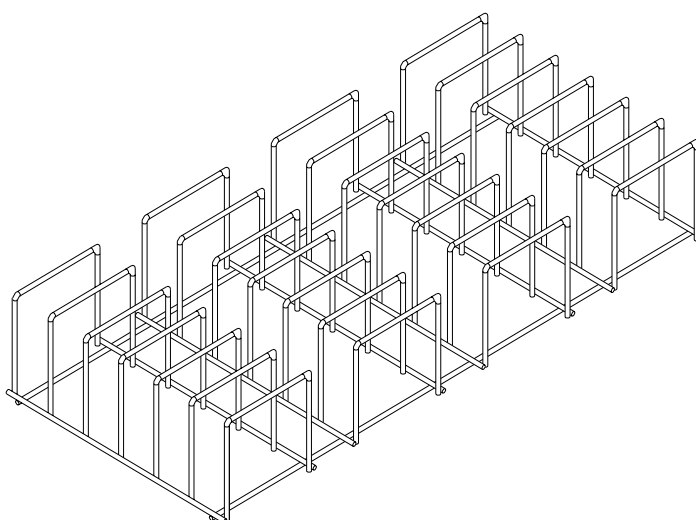

TYPE	CAT No.
2340	ACS215-0008
2540	
3870	ACS215-0010

TRAY

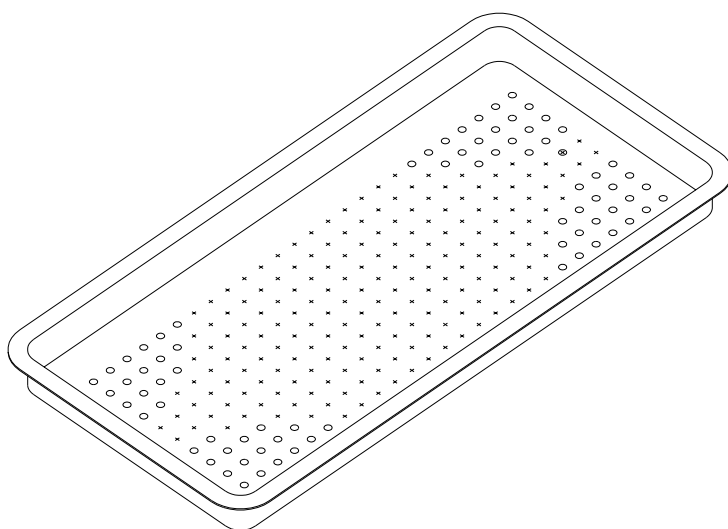

MODEL	SIZE	CAT. No.
1730		TRY173-0001
2340		TRY240-0001
2540		TRY240-0001
3140	Big	TRY314-0001
	Small	TRY314-0002
3850	Big	TRY385-0003
	Small	TRY385-0004
3870	Big	TRY387-0001
	Small	TRY387-0003

TRAY HOLDER

MODEL	TRAY HOLDER CAT. NO.
1730	TRH173-0001
2340	TRH234-0001
2540	TRH254-0001
3140	TRH314-0000
3850	TRH385-0001
3870	TRH387-0001

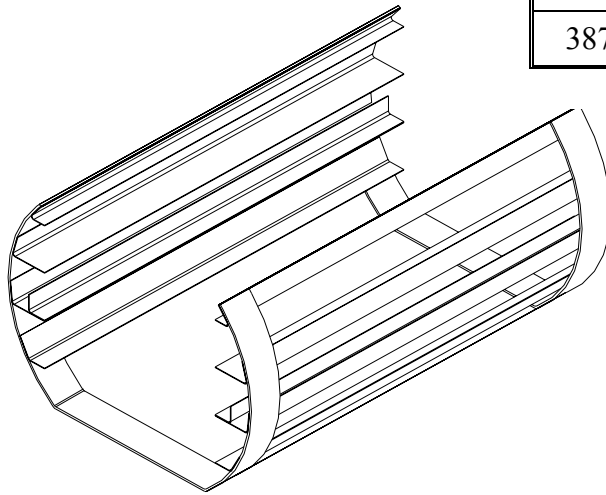

ALTERNATIVE TRAY HOLDER

These tray holders are designed for use in models 2340 & 2540 only.

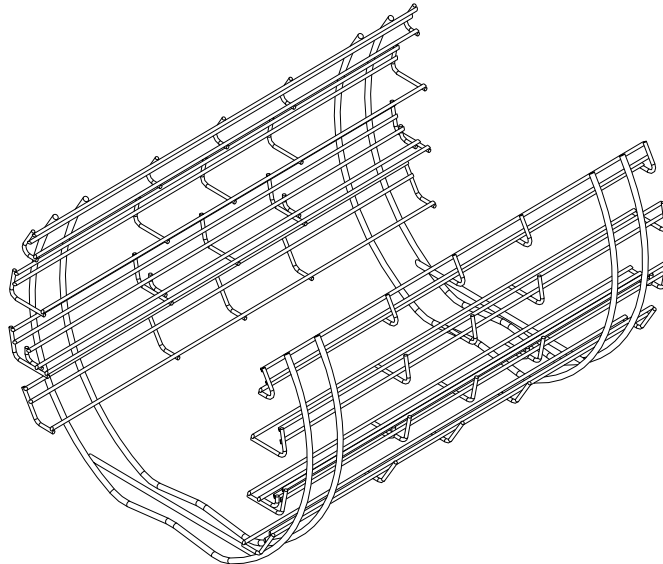

Model	Tray holder cat. No.
2340	TRH234-0008
2540	TRH254-0009

11 LIST OF ACCESSORIES

<i>Description</i>		<i>Cat. No.</i>					
		<i>1730</i>	<i>2340</i>	<i>2540</i>	<i>3140</i>	<i>3850</i>	<i>3870</i>
Handle, Tray, TTA 1730, 2340, 2540		CMT240-0001	CMT240-0001	CMT240-0001	—	—	—
Pouch Rack		—	ACS215-0008	ACS215-0008	—	—	ACS215-0010
Tray	Big	TRY173-0001	TRY240-0001	TRY240-0001	TRY314-0001	TRY385-0003	TRY387-0001
	Small				TRY314-0002	TRY385-0004	TRY387-0003
Holder, Tray		TRH173-0002	TRH234-0001	TRH254-0001	TRH314-0000	TRH385-0001	TRH387-0002
Holder, Tray, Wire		—	TRH234-0008	TRH254-0009	—	—	—
Silicon drain tube		GAS084-0007	GAS084-0007	GAS084-0007	GAS084-0007	GAS084-0007	GAS084-0007
Cleaning Powder, Chamber Brite, 1 Box		CLE096-0026	CLE096-0026	CLE096-0026	CLE096-0026	CLE096-0026	CLE096-0026

12 *CONVERSION TABLE*

<i>°F</i>	<i>°C</i>	<i>psi</i>	<i>Bar</i>
212	100	0	0
234	112	7.4	0.5
250	121	18.0	1.2
262	128	22.2	1.5
273	134	29.6	2.0
282	139	37.0	2.5
291	144	44.4	3.0



Michelle Booth

Co-Owner

Specializing in New & Pre Owned Medical Equipment Sales

7510 Highway 5 North
Alexander, Arkansas 72002
Office: (501) 847-2332
1-888-729-2332

Established in 1986
Cell: (501) 590-8433
Fax: (501) 847-2334
michelle@boothmed.com